

UGELLO  
NOZZLE MODEL

**MP**

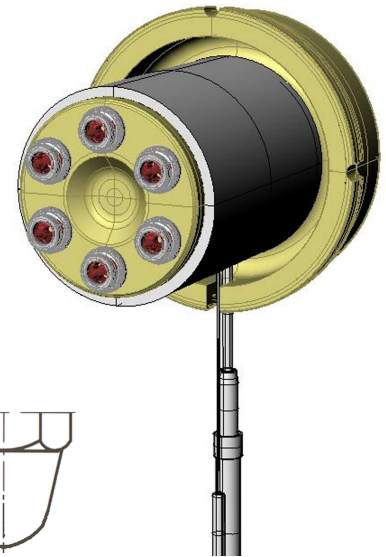

$$T.E = L \times 0.000012 \times \Delta T$$

$$\Delta T = \text{NOZZLE TEMP} - \text{MOLD TEMP } ^\circ\text{C}$$

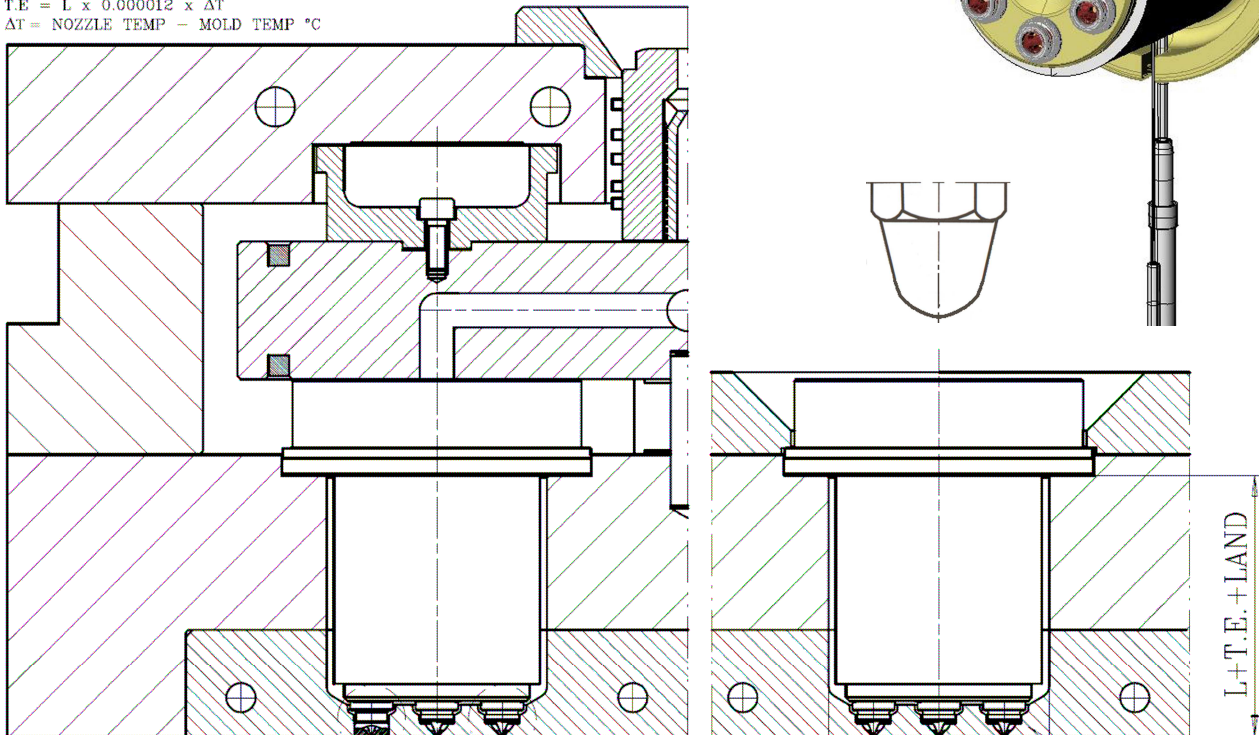

“BN”  
GATE  
STYLE

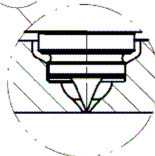
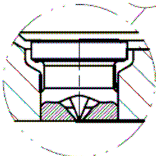

“TN”  
GATE  
STYLE

R  
 $\phi 66.0^{+0.5}_{-0}$  ( $\phi_{\text{Max.}}$ )

N



### UGELLO INIEZIONE MULTIPLA MULTIPOINT NOZZLE

FORNIBILI CON UN NUMERO “N” DI PUNTI DI INIEZIONE VARIABILE DA 2 A 9, SU UN RAGGIO “R” VARIABILE DA Min. 15 A Max. 20mm E UNA “L” Min. PARI A 76 mm ADATTO PER UN PIU' RAPIDO CAMBIO COLORE/MATERIALE.

PER STUDIO APPLICAZIONE SPECIFICA, CONTATTARE IL NS. UFFICIO TECNICO.

SUPPLIED WITH A NUMBER “N” OF GATES FROM 2 UP TO 9, WITH RADIUS “R” FROM MIN. 15 TO MAX. 20mm, AND “L” MIN. 76mm SUITABLE FOR FASTER COLOUR/MATERIAL CHANGE.

FOR YOUR SPECIFIC APPLICATION, PLEASE CONTACT OUR TECHNICAL OFFICE.

Come procedere alla richiesta d'offerta / How to ask for an enquiry

Serie + Model + N + R + L + Tipo / Type [ Flat – O-Ring – Radius ] + Gate style [ TN – BN ]

Ex. MRT-MP 61876 F TN